



XXXI TROFEO MARCO RIZZOTTI

International Optimist Class Team Race
Venice, May 18th – 21th 2017



SAILING INSTRUCTIONS

JURISDICTION AND RACE MANAGEMENT

INTERNATIONAL JURY

| | | | | |
|--------------|---------------|-------------------|------------------|------------|
| 1. Piero | OCCHETTO | Chief Umpire | <i>IU / IJ</i> | <i>ITA</i> |
| 2. Bruce | HEBBERT | Dep. Chief Umpire | <i>IU / NJ</i> | <i>GBR</i> |
| 3. Manuel | HUENSCH | Jury Chairman | <i>IU / IJ</i> | <i>GER</i> |
| 4. Heiko | FALCH | Umpire | <i>IU / NJ</i> | <i>GER</i> |
| 5. Pinar | COSKUNER | Jury | <i>IJ / NU</i> | <i>TUR</i> |
| 6. Arnaud | MANTE | Umpire | <i>IU / NJ</i> | <i>FRA</i> |
| 7. Boguslaw | MOCZORODYNSK | Jury | <i>NU / IJ</i> | <i>POL</i> |
| 8. Oleg | ILYIN | Umpire | <i>IU / IJ</i> | <i>RUS</i> |
| 9. Ilker | BAYINDIR | Umpire | <i>IJ / NU</i> | <i>TUR</i> |
| 10. Philip | MOCZORODYNSKI | Jury | <i>NJ / NU</i> | <i>POL</i> |
| 11. Flavio | CARSUGHI | Umpire | <i>NU / NJ</i> | <i>ITA</i> |
| 12. Michele | RICCI | Umpire | <i>NU / NJ</i> | <i>ITA</i> |
| 13. Elisa | D'IPPOLITO | Umpire | <i>NU / NJ</i> | <i>ITA</i> |
| 14. Nicolas | STEFAN | Umpire | <i>NU / NJ</i> | <i>SUI</i> |
| 15. A.Ayilin | SUNTAY | Umpire | <i>NU / NJ</i> | <i>TUR</i> |
| 16. Greg | EATON | Umpire | <i>NU / NJ</i> | <i>GBR</i> |
| 17. Anna | CUCCIA | Umpire | <i>NJ / obs.</i> | <i>ITA</i> |

RACE COMMITTEE

| | | |
|-------------|-------------|------------------|
| 1. Adolfo | VILLANI | <i>IRO / ITA</i> |
| 2. Giovanni | B. ALBRIZZI | <i>NRO / ITA</i> |
| 3. Paolo | BIANCHINI | <i>NRO / ITA</i> |
| 4. Massimo | SCARPA | <i>NRO / ITA</i> |
| 5. Anna | GIACOMELLO | <i>RRO / ITA</i> |
| 6. Natalina | FRACASSO | <i>RRO / ITA</i> |
| 7. Luisa | FRANZA | <i>RRO / ITA</i> |
| 8. Guido | TURRA | <i>RRO / ITA</i> |

1 RULES

- 1.1 The event will be governed by the rules as defined in The Racing Rules of Sailing 2017-2020.
- 1.2 Appendix D – Team Racing Rules will apply and races will be umpired.
- 1.3 RRS D1.1(d) is deleted
- 1.4 The “class rules” for the purposes of the definition of “rules” are the International Optimist Association Class Rules.
- 1.5 Decisions of the Protest Committee will be final as provided in RRS 70.5(a).
- 1.6 If there is a conflict between languages the English text will take precedence.
- 1.7 In case of conflict between the Notice of Race and the Sailing Instructions, the Sailing Instructions will take precedence. This changes RRS 63.7.

2 - ELEGIBILITY

- 2.1 To become eligible a team shall register as required by the notice of race or, if not specified, on arrival at the event. The team shall provide any required damage deposit before going afloat for the first time.
- 2.2 A registered team shall change its members only in exceptional circumstances and only with the permission of the race committee. There will be no right to request redress from any party concerning such changes, altering RRS 60.1(b) (redress).

3 - NOTICES to COMPETITORS

The official notice board will be located in front of the Regatta Office, located at the Camping Marina di Venezia.

4 - CHANGES in SAILING INSTRUCTIONS

- 4.1 Any written changes to the Sailing Instructions or the schedule will be approved by the Principle Race Officer, signalled by flying flag L from the shore signal position and posted immediately after the Participants’ Meeting on the day it will take effect. Any change to the schedule requiring racing to begin earlier than scheduled will be posted by 2100 hours on the day before the scheduled change takes effect and will be posted on the Official Notice Board.
- 4.2 Any oral changes to the sailing instructions on the water will be signalled with the display of the third substitute and communicated to each team by the Race Committee and/or umpires, and will be effective immediately. These changes will also be communicated to coaches on a VHF channel and posted on the official notice board at the end of that day’s racing.

5 - SIGNALS MADE ASHORE

- 5.1 Signals made ashore will be displayed on the flag pole located close to the boats area.
- 5.2 When AP is displayed ashore, “1 minute” is replaced with “not less than 30 minutes” in the race signal AP. This changes race signal AP.

6 - EVENT SCHEDULE

| Day | Date | Time | Description |
|-----|--------|-------------|--|
| 1 | 18 May | 15.00-20.00 | On-site registration |
| | | 19.00 | Competitors Meeting (Mandatory) |
| 2 | 19 May | 09.00 | Competitors Meeting (Mandatory) |
| | | 11.00 | First Warning Signal |
| | | - | Umpires and Competitors debrief after racing |
| 3 | 20 May | 09.00 | Competitors Meeting (Mandatory) |
| | | 11.00 | First Warning Signal |
| | | - | Umpires and Competitors debrief after racing |
| 4 | 21 May | 09.00 | Competitors Meeting (Mandatory) |
| | | 11.00 | First Warning Signal |
| | | 16.30 | Last Attention Signal |
| | | - | Umpires and Competitors debrief after racing |
| | | 19.00 | Awards ceremony |

FORMAT

- 6.1 The event will be a four boat against four boat team race. For teams having five competitors, any four may compete in a race, so long as the fifth competitor remains in the area designated for coaches from the warning signal of that race until that race has been completed
- 6.2 The format of the event is a Round Robin series where every team sails other teams according to the posted schedule. The format may be modified during the event in a fair and practical way as solely determined by the race committee taking into account the entries, weather conditions, time constraints and any other relevant factors.
- The format of the event may be changed during the event by the Principal Race Officer in conjunction with the Chief Umpire and the Jury Chairman in an even way after considering the number of entries, the weather conditions, the sailable time available and other relevant factors.
- Rizzotti Trophy will be awarded whatever will be the number of sailed races. (This changes RRS D4.2(b).)
- 6.3 In the event that the round robin is completed a further format may be sailed as communicated per SI 4.
- 6.4 The schedule of races will be displayed on the official notice board. Any changes thereto and schedules for subsequent rounds will be displayed not less than 10 minutes before the start of that phase of the competition.
- 6.5 Every race will be assigned a race number in the race schedule. The schedule of races will be given to each team at least 60 minutes before starting racing.
- 6.6 The race committee may at any time remove a particular race from the published sequence of races and run it at a later time
- 6.7 Each team shall be assigned a unique colored set of Identification stickers, letters for the team and numbers for the boat, which shall not be reduced in size in any dimension and shall be securely attached to the stern and to the first 20% of the forward part of each side of the hull, as stated in Appendix A to these Sailing Instructions.

7 - COURSES and CHANGE of COURSE

- 7.1 The course located in front of the beach of the Camping Marina di Venezia, Cavallino - Venice, will be identified by a YELLOW flag with 'RC' in green letters conspicuously displayed on the signal boat.
- 7.2 The course shall be as in the diagram in Appendix B to these sailing instructions. After finishing when returning to the waiting area all boats shall leave the finish boat and marks 4 and 3 to starboard at a minimum distance of 50 meters and shall not interfere with boats racing.
- 7.3 The Race Committee may move marks of the course. RRS 33 will not apply. The moving of a mark by the Race Committee will not be grounds for a boat to request redress. This changes RRS 60.1(b).
- 7.4 Courses will not be shortened. This changes RRS 32.
- 7.5 The Race Committee will set the course length in order to race for about 10 minutes. A different duration of the race will not be grounds for a request for redress from a team or a boat.
- 7.6 Unless otherwise specified in the appendix to these SIs, the time limit for each race will be 20 minutes. Boats failing to finish within five minutes after the first boat finishes will be scored DNF. This changes RRS 35.

8 - MARKS – START - FINISH

Marks will be as follows:

| Course Marks | Starting Pin End | Finishing Mark |
|-----------------|------------------|----------------|
| Orange cylinder | White cylinder | White cylinder |

- 8.1 The starting line shall be between the staff with an orange flag on the Race Committee Start boat and the pin-end mark described in SI 8 at the other end of the line.
- 8.2 The finishing line shall be between the staff with a blue flag on the Race Committee Finish boat and the inflatable mark described in SI 8.

9 - THE START

- 9.1 Rule 26 (starting system) and related Race Signals will not apply.
- 9.2 Sound signals will prevail. Failure to hear a signal shall not be grounds for a boat to request redress. This changes RRS 60.1(b).
- 9.3 The race number will be displayed on the leeward side of the committee boat before the warning signal. When the race number is displayed in this way it overrides all prior communications, schedules or instructions.

The Race Committee may at any time remove a particular race from the published sequence of races and run it at a later time.

Attention may be drawn to an imminent warning signal by a series of short sound signals. If flag AP has been displayed, these signals may be used in place of the standard one minute interval. This changes race signal AP.

9.4 The starting sequence will be:

| Signal | Min. to start | Sound signal | Alternative Visual signals | |
|-------------|---------------|--------------|----------------------------|------------|
| Warning | 3 | One | Trofeo Rizzotti Flag UP | 3 battens |
| Preparatory | 2 | One | Code flag P UP | 2 battens |
| One-minute | 1 | One | Code flag P DOWN | 1 batten |
| Start | 0 | One | Trofeo Rizzotti Flag DOWN | No battens |

Note: The warning signal of the following match may be displayed together with the starting signal of the previous match or later.

10 - RECALLS

- 10.1 When a boat is subject to rule 29.1 flag X need not be displayed for more than 1 minute after the starting signal; this amends rule 29.1. The Race Committee shall hail the bow numbers and letters of premature starters.
- 10.2 An erroneous call or the failure to hear one shall not be grounds for a boat to request redress. This changes rule 60.1(b).
- 10.3 A boat that fails to start within two minutes of her starting signal will be scored DNS without a hearing. However, if the boat was OCS at her starting signal and did not return to start properly she shall be scored in accordance with rule D3.1(b) without a hearing. This amends rules A4 and A5.
- 10.4 After a general recall succeeding races may be delayed for the recalled race. Attention is drawn to SI 9.3.

11 - PROTESTS AND PENALTIES

- 11.1 Protests and requests for redress for incidents afloat shall be delivered to the finishing boat within 3 minutes from the end of the race.
- 11.2 The protest committee may refuse to hear a protest or request for redress unless it's outcome is relevant to progress, but not seeding, in the next round of the competition. This amends rule 63.1.
- 11.3 When rule D2.2 applies and the race umpires together with one other umpire (when available) decide that a boat has broken rule 14 and there is damage or injury, they may penalize her team by half a race win without a hearing. The boat will be informed as soon as practical and may request a hearing. Any penalty after a hearing will be in accordance with rule D3.1(c). This amends rule 63.1.
- 11.4 When a competitor breaks safety rules (personal flotation device) the competitor's team shall be penalized one race win without a hearing. This amends rule 63.1.
- 11.5 When a protest committee decides that a breach of a rule has had no significant effect on the outcome of a race, it may make any arrangement it decides is equitable, which may be to order a re-sail or to impose no penalty. This amends rule D3.1.
- 11.6 Only the race committee or protest committee may protest for infringement of class rules.
- 11.7 Measurement protest can be lodged only by the Race Committee, the International Jury or the Technical Committee. This changed Rule 60.1.

12 - SCORING

- 12.1 RRS D3 shall apply.
- 12.2 An OCS boat not having sailed completely back to the pre-start side of the starting line, in order to properly start her race, will be considered having gained a significant advantage for her team and the RC will score her as per D3.1(b) without hearing.

13 - UMPIRE BOATS

The umpire boats shall fly a black flag with yellow letter "U".

14 - COACH BOATS

- 14.1 Each team is allowed one designated coach boat, and each coach is required to carry a working VHF radio, a suitable anchor and an anchor line sufficient to anchor safely in the designated waiting area .
- 14.2 Coach and spectator boats shall remain anchored in the waiting area designated on the course diagram, unless otherwise directed by the Race Committee and/or Umpires for safety purposes.
- 14.3 Coach boats must expose a white flag with blue letter T, to collect at Race Office.

15 SAFETY

- 15.1 Each competitor must wear a personal flotation device (PFD), properly secured at all times, with a whistle attached, from dock to dock except when temporarily adding or removing clothing. Wet suits, dry suits and inflatable PFD's do not constitute adequate personal buoyancy. Failure to wear one while racing may result in penalty points added to the boat's score at the discretion of the protest committee.
- 15.2 A competitor retiring from a race shall notify a race committee or safety boat before leaving the course area and notify the race committee immediately upon returning to shore.

16 - Spare

17 - PRIZES

Prizes will be awarded in accordance with the Notice of Race.

18 - DISCLAIMER of LIABILITY, INSURANCE

- 18.1 A boat is entirely responsible for her own safety, whether afloat or ashore, and nothing, whether in the Notice of Race or Sailing Instructions or anywhere else, reduces this responsibility.
- 18.2 It is for the boat to decide whether she is fit to sail in the conditions in which she will find herself. By launching or going to sea, the boat confirms that she is fit for those conditions and that her crew is competent to sail and compete in them.
- 18.3 When the boats are provided by the competitors, the boat is required to hold adequate insurance and in particular to hold insurance against third party claims as required by the notice of race or, if not specified, in the sum of at least 1,500,000 Euros.
- 18.4 Nothing done by the organizers can reduce the responsibility of the boat nor will it make the organizers responsible for any loss, damage, death or personal injury, however it may have occurred, as a result of the boat taking part in the racing. The organizers encompass everyone helping to run the race and the event, and include the organizing authority, the race committee, the race officer, umpires, patrol boats and beach-masters.
- 18.5 The provision of security boats does not relieve the boat of her responsibilities

APPENDIX "A"

Identification badges, both for the teams (letters) and for the single competitor (numbers) shall be stuck on the starboard and port sides and on transom as shown in the diagram.

The stickers of the sponsors shall be stuck on both sides of the hull, in accordance with Regulation 20 - ISAF Advertising Code.

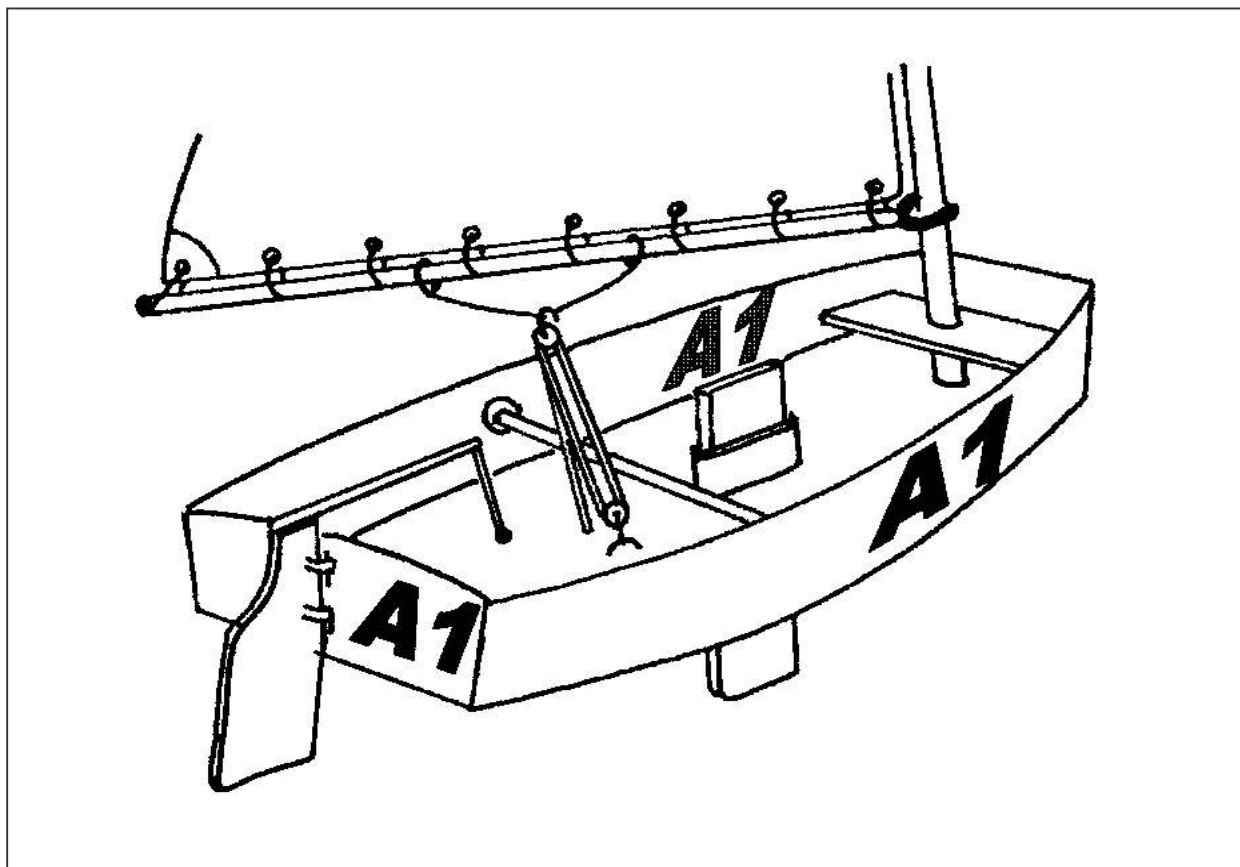

APPENDIX "B"

Diagram and Description of the Course

